

1

2

3

4

5

6

7

A

A

P1

P2

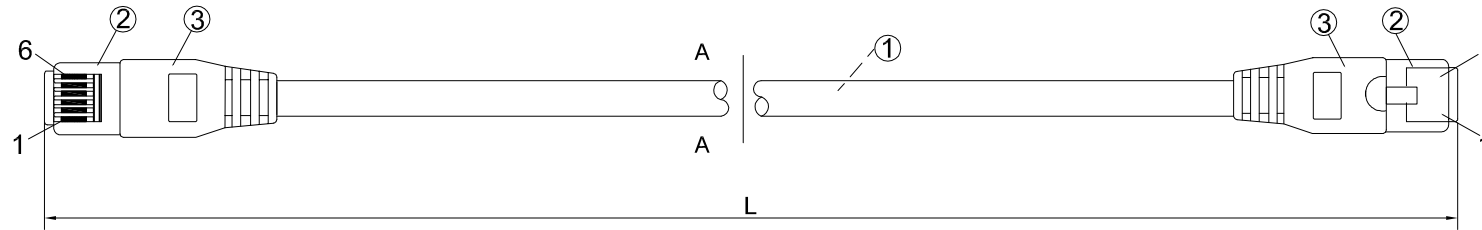

PACKAGE: Bulk(100pcs PE Bag)

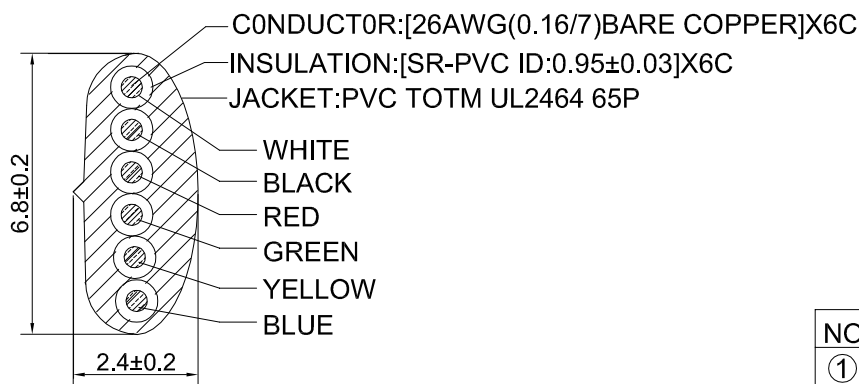

P1		P2	
1	WHITE	1	
2	BLACK	2	
3	RED	3	
4	GREEN	4	
5	YELLOW	5	
6	BLUE	6	

NO	ITEM	DESCRIPTION	Q'TY
①	CABLE	L=610±20, Gray(S49-1) LIGHT	1PCS
②	PLUG	6P6C Long type 50U" Square hole	2PCS
③	BOOT	PVC 80P Gray ③	2PCS

RoHS compliant
Unit: mm

Scale	Free					Date	Name	Customer-No.	
TOLERANCE						Drawn	28.02.2018	Amy	4038584-02
X.	±0.50								
.X	±0.35	③	Correct boot color	12.04.2018	Amy	Approved	12.04.2018	Amy	ASSMANN WSW-No. KAB 6609-1
.XX	±0.15	②	Add customer part number	10.04.2018	Amy				
.XXX	±0.05	①	Add conn/boot drawing on page 2/3	05.03.2018	Amy				Drawing-No.
DIM	TOL	①	Add conn/boot drawing on page 2/3	05.03.2018	Amy				ASS 8205 CA
		①	Drawn	28.02.2018	Amy				rev03
Angle	±3°	Id.	Modification						Replace
									SHEET 1 / 3



G

G

H

H

1

2

3

4

5

6

7

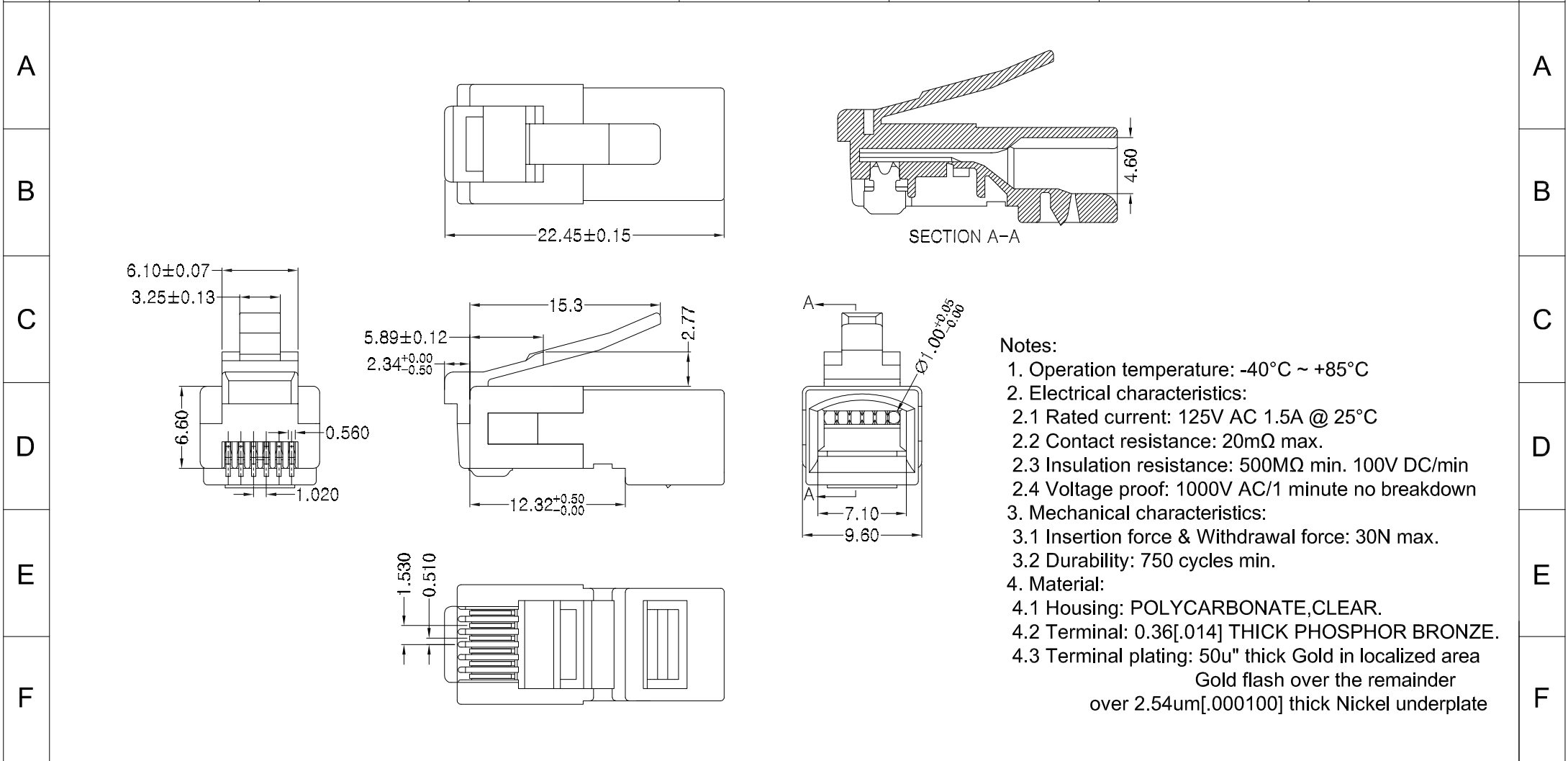

- Notes:**
- Operation temperature: -40°C ~ +85°C
 - Electrical characteristics:
 - Rated current: 125V AC 1.5A @ 25°C
 - Contact resistance: 20mΩ max.
 - Insulation resistance: 500MΩ min. 100V DC/min
 - Voltage proof: 1000V AC/1 minute no breakdown
 - Mechanical characteristics:
 - Insertion force & Withdrawal force: 30N max.
 - Durability: 750 cycles min.
 - Material:
 - Housing: POLYCARBONATE,CLEAR.
 - Terminal: 0.36[.014] THICK PHOSPHOR BRONZE.
 - Terminal plating: 50u" thick Gold in localized area
Gold flash over the remainder
over 2.54um[.000100] thick Nickel underplate

RoHS compliant
Unit: mm

Scale	Free					Date	Name	Customer-No.
TOLERANCE					Drawn	28.02.2018	Amy	4038584-02
.X	±0.20	③	Correct boot color	12.04.2018	Amy	Approved	12.04.2018	ASSMANN WSW-No.
.XX	±0.10	②	Add customer part number	10.04.2018	Amy			KAB 6609-1
.XXX	±0.05	①	Add conn/boot drawing on page 2/3	05.03.2018	Amy			Drawing-No.
DIM	TOL	①	Drawn	28.02.2018	Amy			ASS 8206 CA
Angle	±2°	Id.	Modification	Date	Name			Replace
								SHEET
								2 / 3

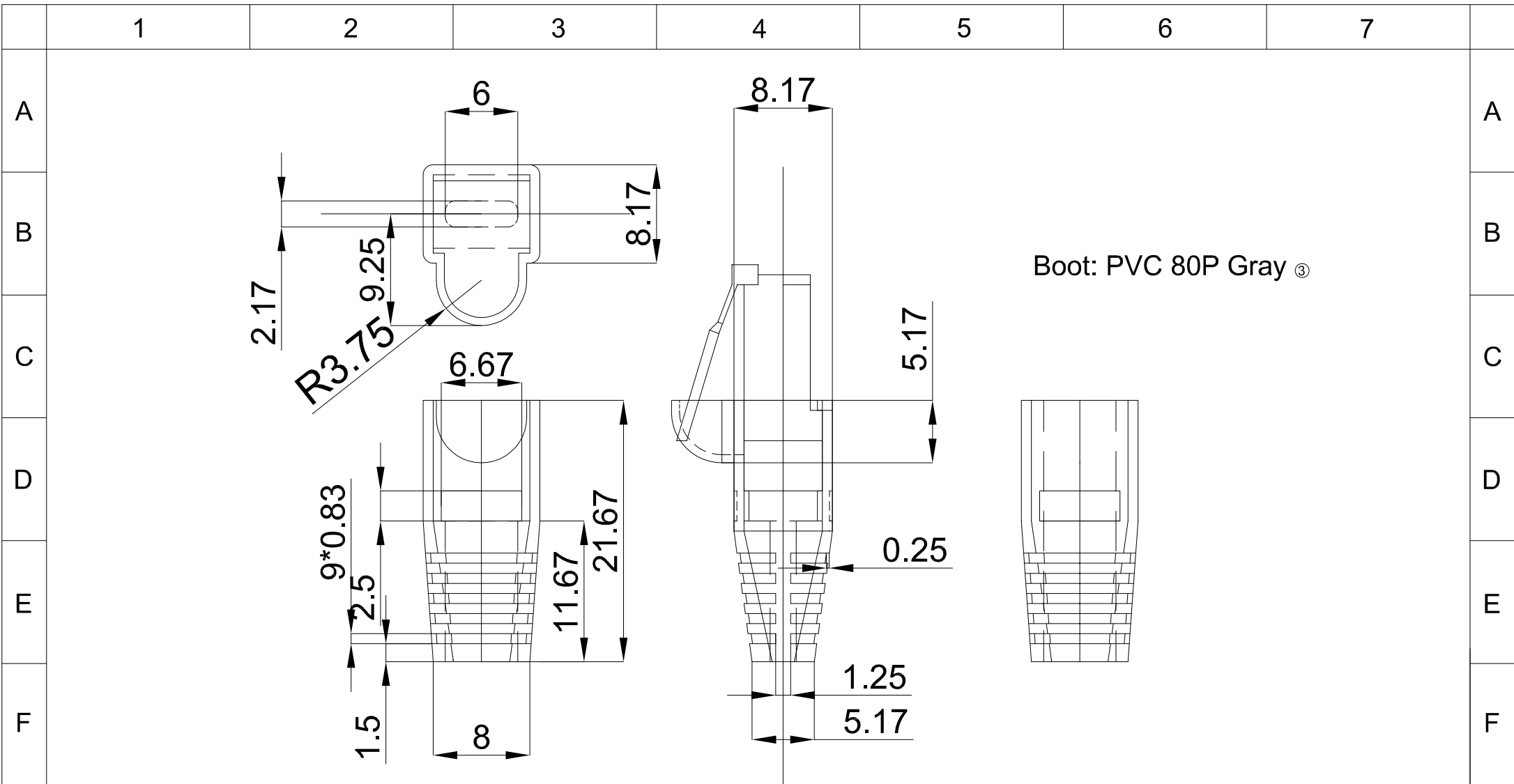

RoHS compliant
Unit: mm

Scale	Free						Date	Name	Customer-No.
TOLERANCE						Drawn	28.02.2018	Amy	4038584-02
X.	±0.50	③	Correct boot color	12.04.2018	Amy	Approved	12.04.2018	Amy	ASSMANN WSW-No.
.X	±0.35	②	Add customer part number	10.04.2018	Amy				KAB 6609-1
.XX	±0.15	①	Add conn/boot drawing on page 2/3	05.03.2018	Amy				Drawing-No.
.XXX	±0.05	①	Add conn/boot drawing on page 2/3	05.03.2018	Amy				ASS 8206 CA
DIM	TOL	①	Drawn	28.02.2018	Amy				rev03
Angle	±3°	Id.	Modification	Date	Name			Replace	SHEET
									3 / 3